

Retrofit without Compromise

GE High Output LED Lamps



GE imagination at work

GE High Output LED Lamps

GE's innovative high output LED retrofit lamp solutions offer substantial opportunities to reduce energy consumption and maintenance costs in applications where directional, high quality light is required.

Offering low cost of ownership, and with paybacks of less than 1 year in professional applications, these lamps are TRUE retrofits that require no compromise to achieve dramatic through-life savings:

- Lamps are the same size as their incandescent or halogen equivalents, having been designed around the international standard outline
- Peak intensity (candela) and beam angle match incandescent or halogen equivalents
- Lamps are available in warm white colour temperatures (2700K-3100K)
- Excellent CRI >80
- High Power Factor >90%

In addition, these lamps offer all of the benefits that LED technology is known for: Extra long life, no heat, UV or IR in the beam, and entirely mercury-free.

LED Case Study

How LED can save money and help the environment

In this example, a hotel containing 1000 20W halogen GU10 lamps was retrofitted with GE LED GU10 4W lamps. Lamps were situated in rooms burning 6 hours per day, and in corridors burning 24 hours per day. Average burn time was assumed to be 4000 hours per year per lamp.

Benefits achieved were:

- 80% saving in energy consumption and CO₂ emissions
- 62% reduction in total cost of ownership over 5 years
- Payback in less than 1 year



5 year cost of ownership

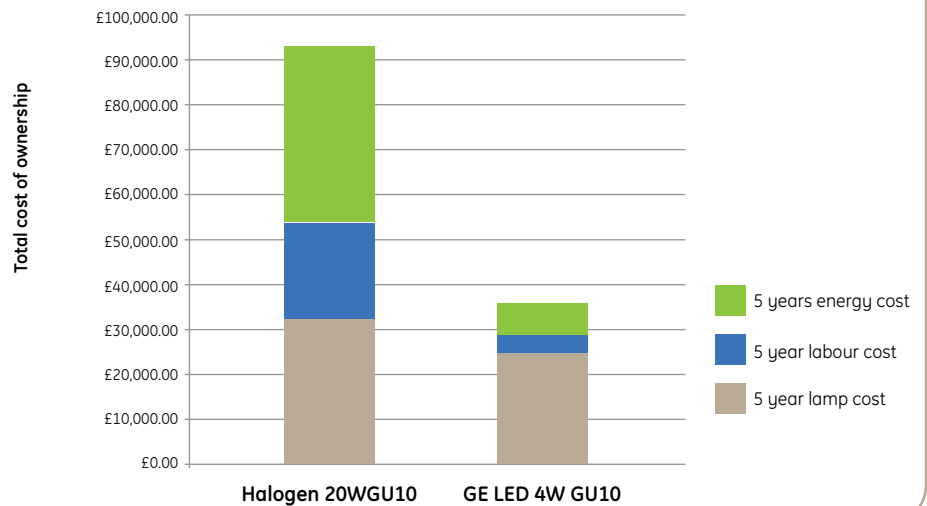

Payback

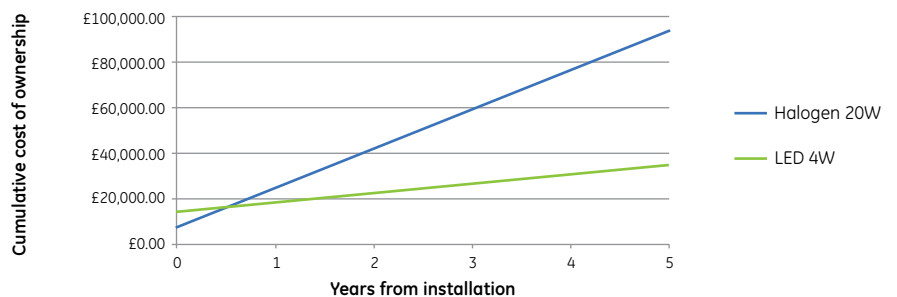

CO₂ emitted per hotel per year

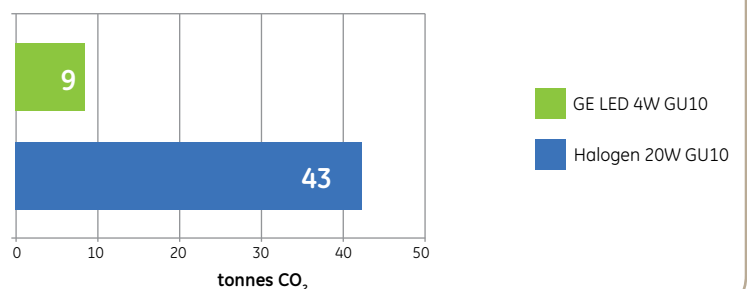

Assumptions Energy cost of £0.10 per kWh. 0.536 kg CO₂ emitted per kWh (European average from Eco-Invent). 4000 operational hours per year. NOTE theoretical 'typical' example only. All applications will vary.

High Output LED Retrofit Lamps

LED 4 Watt GU10 Lamps

Energy saving

- 12% higher candela than 20W GU10 halogen lamps
- Same 36° beam angle as 20W GU10 halogen lamps
- Consumes 80% less energy than 20W halogen GU10

Low maintenance costs

- Long life – 15,000 hours to 70% lumen output

High quality light

- Warm white 3100K with CRI >80

Easy installation

- Same size as halogen GU10 lamps
- Uses industry standard GU10 base

Main applications

- Downlighting and accent lighting in domestic and commercial (hotel, retail, leisure etc) applications

Sustainable solution

- No mercury
- 80% energy saving
- No UV, IR or heat in beam
- High power factor



LED 4 Watt R50 Lamps

Energy saving

- Similar candela to 40W R50 incandescent lamps
- Same 36° beam angle as 40W incandescent R50 lamps
- Consumes 90% less energy than 40W incandescent R50

Low maintenance costs

- Long life – 15,000 hours to 70% lumen output

High quality light

- Warm white 3100K with CRI >80

Easy installation

- Same size as incandescent R50 lamps
- Uses industry standard E14 base

Main applications

- Downlighting and accent lighting in domestic and commercial (hotel, retail, leisure etc) applications

Sustainable solution

- No mercury
- 90% energy saving
- No UV, IR or heat in beam
- High power factor

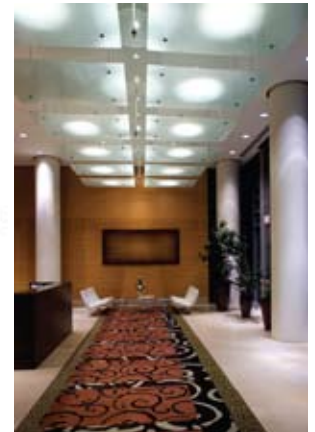
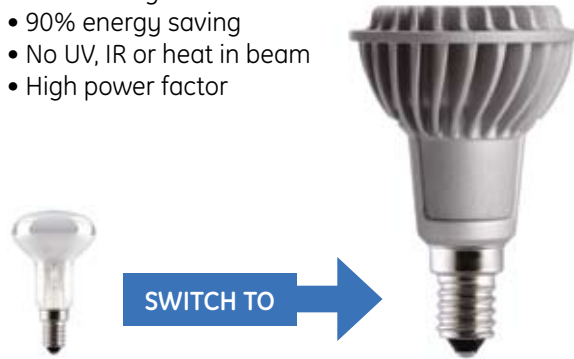

LED 7 Watt R63 Lamps

Energy saving

- Similar candela to 60W R63 incandescent lamps (36° version)
- 20% more candela than 50W halogen PAR20 lamps (20° version)
- Similar beam angle to incandescent R63 lamps (36° version)
- Consumes almost 90% less energy than 60W incandescent R63 and 86% less energy than 50W halogen PAR20

Low maintenance costs

- Long life – 20,000 hours to 70% lumen output

High quality light

- Warm white 2700K and 3000K with CRI >80

Easy installation

- Same size as incandescent R63 lamps
- Uses industry standard E27 base

Main applications

- Downlighting and accent lighting in domestic and commercial (hotel, retail, leisure etc) applications

Sustainable solution

- No mercury
- Up to 90% energy saving
- No UV, IR or heat in beam
- High power factor



Distribution of luminous intensity for LED High output lamps

The following diagrams show polar light intensity curves and beam diagrams.

LED 4W GU10 and R50 WFL
Nominal beam angle: 36°

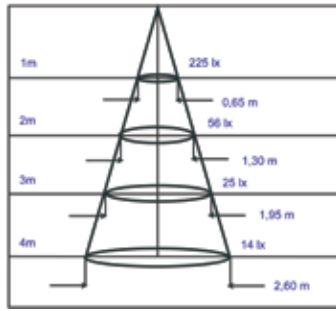

LED 7W R63 WFL
Nominal beam angle: 36°

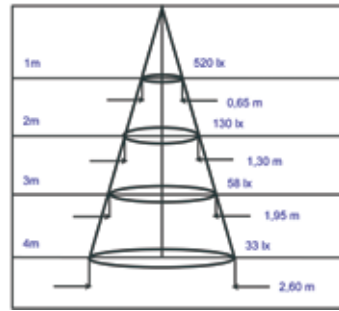

LED 7W R63 FL
Nominal beam angle: 20°

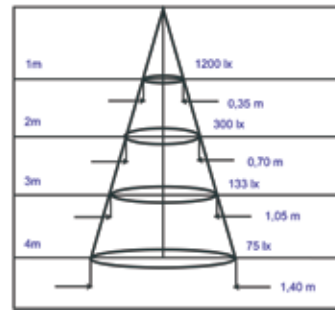

LED 4W GU10 and R50 WFL
Nominal beam angle: 36°

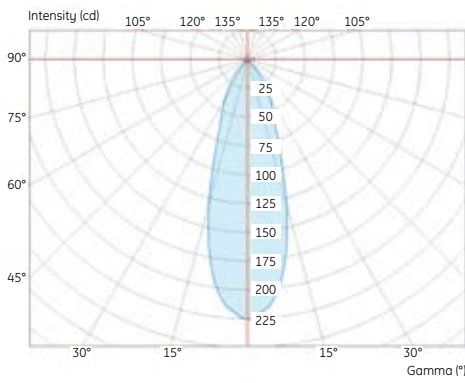

LED 7W R63 WFL
Nominal beam angle: 36°

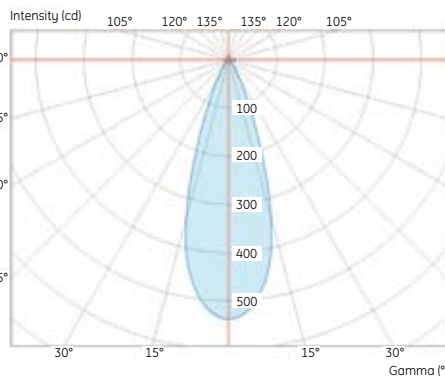

LED 7W R63 FL
Nominal beam angle: 20°

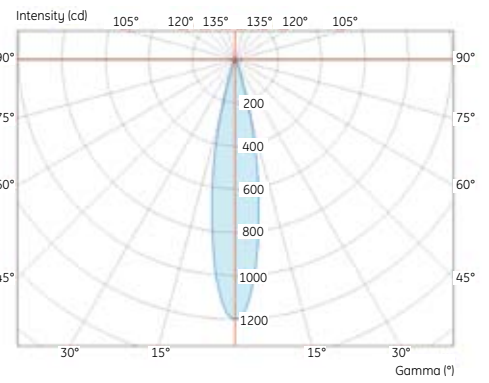

Wattage [W]	Volts [V]	Cap	Product Description	Candela [cd]	Beam Angle [°]	CCT [K]	CRI [Ra]	Life* [L70, h]	Diameter [mm]	Length [mm]	Pack Qty	Product Code
4	230	GU10	LED4/GU10/830/230V/WFL	225	36	3100	80+	15,000	50	57	8	75280
4	240	GU10	LED4/GU10/830/240V/WFL	225	36	3100	80+	15,000	50	57	8	75281
4	230	E14	LED4/R50/830/230V/WFL/E14	225	36	3100	80+	15,000	50	76	8	75288
4	240	E14	LED4/R50/830/240V/WFL/E14	225	36	3100	80+	15,000	50	76	8	75289
7	220-240	E27	LED7/R63/827/220-240V/FL/E27	1200	20	2700	80+	20,000	63	101	8	76093
7	220-240	E27	LED7/R63/827/220-240V/WFL/E27	520	36	2700	80+	20,000	63	101	8	76094
7	220-240	B22	LED7/R63/827/220-240V/FL/B22	1200	20	2700	80+	20,000	63	101	8	76099
7	220-240	B22	LED7/R63/827/220-240V/WFL/B22	520	36	2700	80+	20,000	63	101	8	76100
7	220-240	E27	LED7/R63/830/220-240V/FL/E27	1200	20	3000	80+	20,000	63	101	8	75294
7	220-240	E27	LED7/R63/830/220-240V/WFL/E27	520	36	3000	80+	20,000	63	101	8	75295
7	220-240	B22	LED7/R63/830/220-240V/FL/B22	1200	20	3000	80+	20,000	63	101	8	75296
7	220-240	B22	LED7/R63/830/220-240V/WFL/B22	520	36	3000	80+	20,000	63	101	8	75297

* initial life claim at launch to 70% lumen maintenance. Testing continues to final L70 lifetime